

http://www.smd.co.jp



## SHIMADA MACHINERY CO.,LTD.

**Head Office** 3-1-18 Sawakihama Mito-cho, Toyokawa, Aichi 441-0304  
TEL <0533> 76-3381 FAX <0533> 76-3386

**Yokohama Office** 540-16 Ichigao-cho, Aoba-ku, Yokohama, Kanagawa 225-0024  
TEL <045> 973-4800 FAX <045> 973-4805

\*Specifications are subject to change without prior notice and without any obligation on the part of the manufacturer.

SHIMADA-KITAKO

URL: <http://www.smd.co.jp>

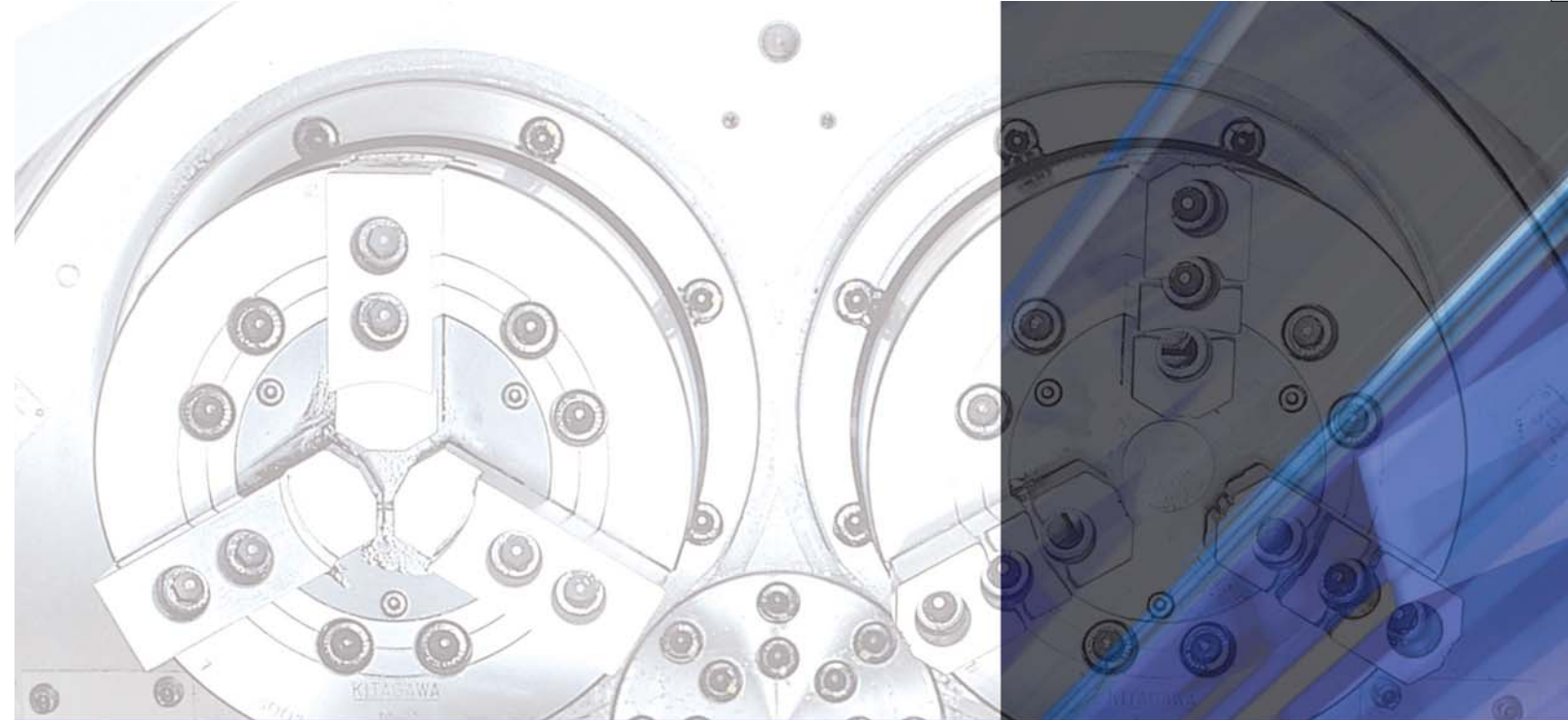

Productive CNC4 Spindles Lathe

# SHIMADA-KITAKO



## HS4200

### HS4200i

Equipped with KITAKO standard high-speed part loading system.

### HS4200iM

Equipped with KITAKO standard high-speed part loading system and live tooling capability.

### HS4200n

Basic model (Loading system optional.)

### HS4200nM

Basic model with live tooling capability. (Loading system optional.)



SYSTEM SALES, INC.

R. Kent Baker  
President

(317) 251-2770 Office

(317) 251-2888 Fax

(317) 431-7191 Cell

[kbaker@cncsystemsales.com](mailto:kbaker@cncsystemsales.com)



● WORK STOCKER (OPTION)



● OPERATION PANEL

● LOADER OPERATION BOX



Ultra High Production CNC Lathe  
with high-speed automatic part loading system.

# HS4200i

**The newest version of the uniquely designed 4-spindle lathe.**  
(two spindles are simultaneously machining while the other two spindles are being loaded or unloaded)

**Part loading/unloading time can literally become close to ZERO.**

**By increasing the rapid feed rate on each axis, idling time of the machine has become minimal, and the actual efficiency has been drastically improved.**

**Built-in, ultra high speed part loading system is on the machine.**

**Variety of machine layout, and many different options, can be offered to meet your different requirements for a line layout.**

- Part loading/unloading process can be performed while the parts are being machined.....resulting “No idle time for part loading/unloading” and “stable & accurate part loading process on the chuck” can be assured.
- 1.5 seconds for carrier indexing time, which is the only time needed for part loading/unloading.※1
- Box slide ways assure high performance in machining close tolerances for a long period of time of usage time, yet rapid feed rates are the highest in its class for box slide ways.
- By flipping the part, first and second operations on the machine.
- Exceptionally good chip disposal design for unmanned operation.
- Different types of parts stackers and other options are available to match your needs for system layout.※2

※1. Shimada's unique feature of the spindle-carrier index makes a part loading/unloading time internal to machining cycle.  
Example: if a machining cycle time is 20 sec., a part to part cycle time will be merely 21.5 sec., equivalent to 0.75 sec. part loading/unloading time per part.

※2. The HS4200n is the right model name when the automatic part loading system is not needed.

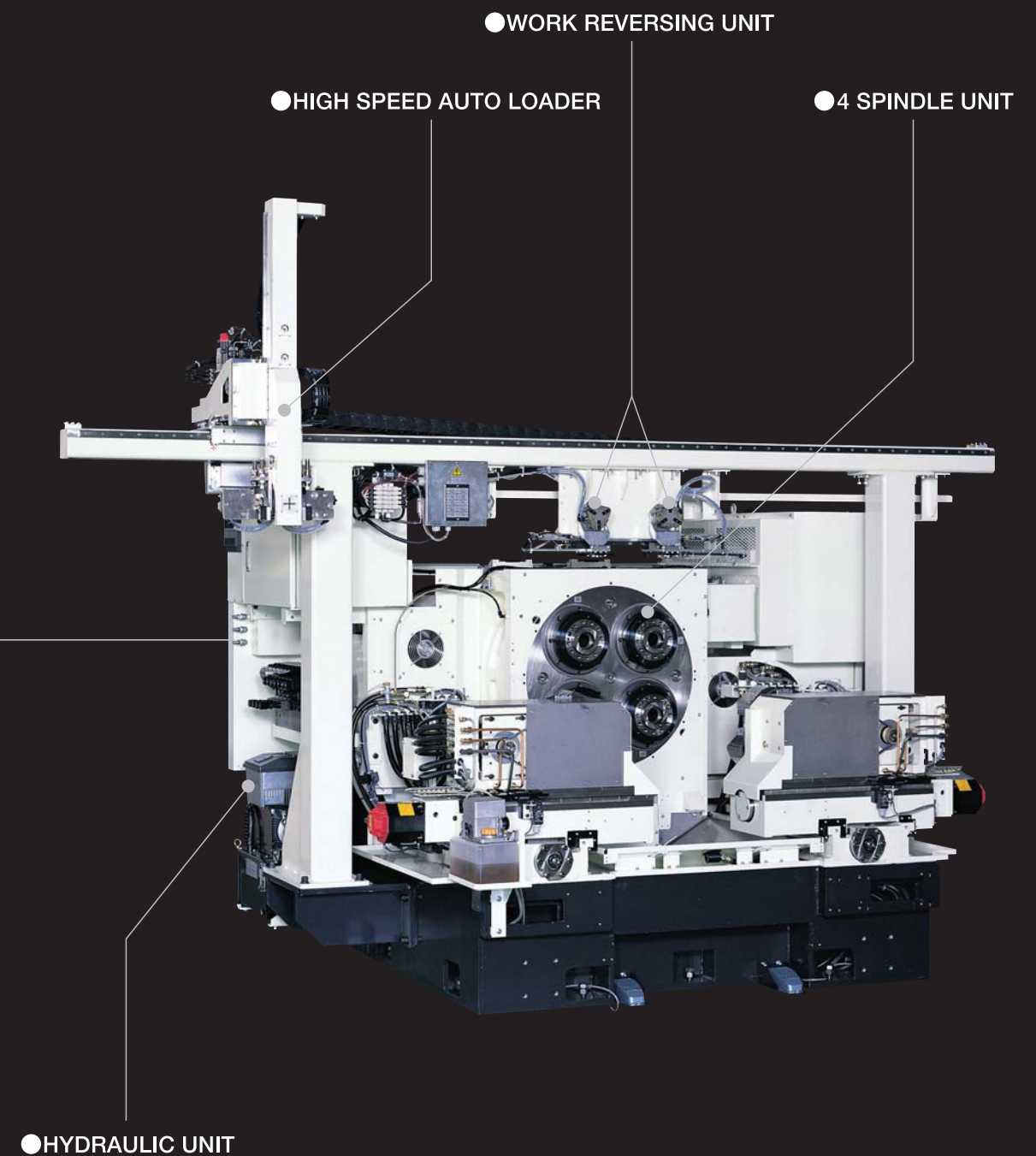



# Breaking Through the Boundaries ... Now, Even Faster

Only 4 Spindles system can. Loading and Unloading is done while machining...Idling time become minimum!

## Structure

### 4 Spindle Unit

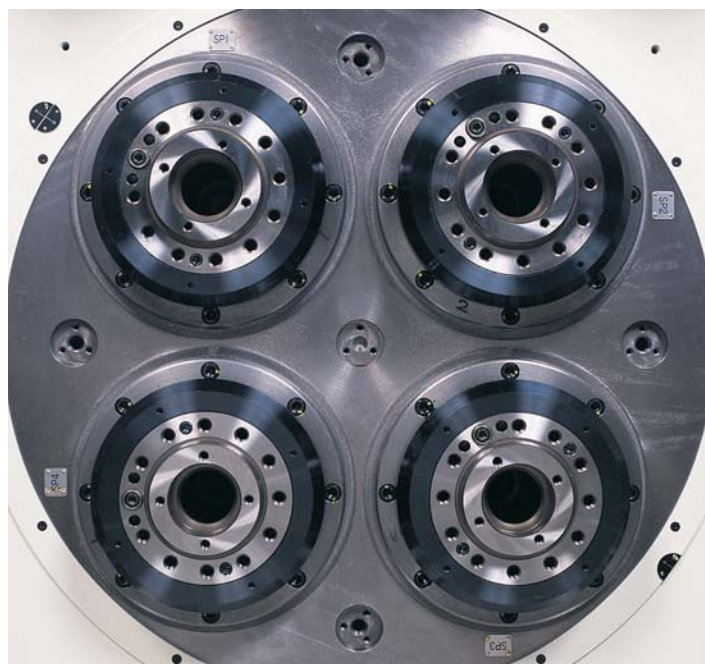

The main spindles are hardened, Precision ground and supported by precision double row cylindrical roller bearings and angular contact bearings. The cartridge type spindles are lubricated with grease and sealed less maintenance.

※Top: Loading/Unloading Area Bottom: Cutting Area

### High Accuracy Indexing

The spindles are mounted in a carrier drum, Whose exterior is a large diameter curvic coupling thus insuring high accuracy, rigidity and repeatability when positioning.

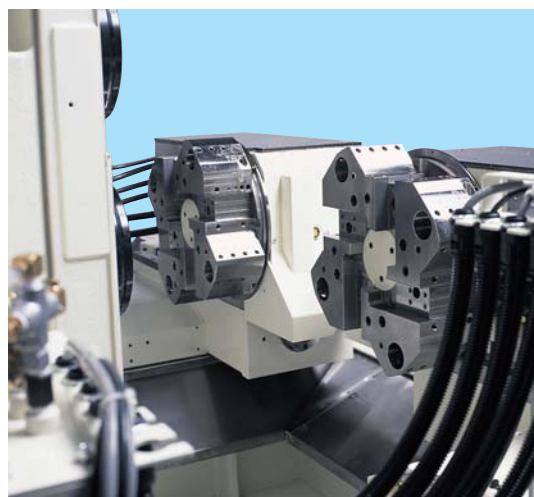
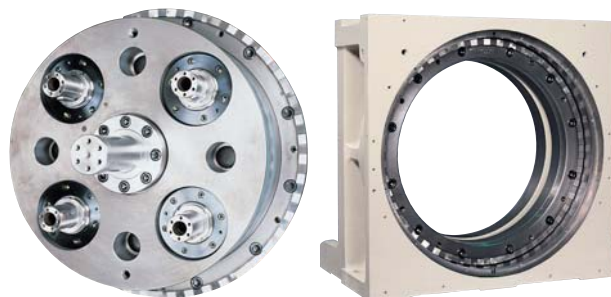

### 8-Station Turrets.

High speed, bi-directional, random indexing employs a revolutionary designed 3-piece curvic-coupling. On optional turrets, OD / ID tooling can be mounted at any position on the tool turrets.

### Chip Conveyor



Hinge type chip conveyor is standard. Other type chip conveyor is available as an option.

※Magnet Scraper, Rolling Drum Filter, etc.

### Hydraulic Unit

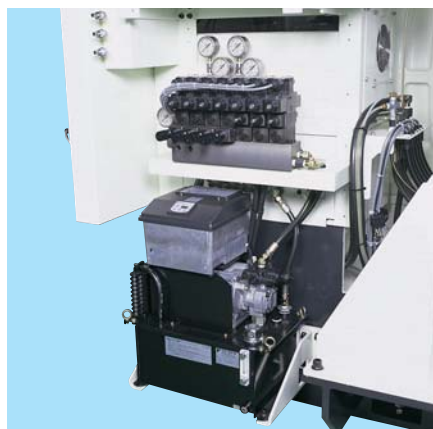

The hydraulic unit has an energy saving pump that comes with an inverter motor.

### Box-Shaped Slideways



To ensure high accuracies and long life, each model is equipped with Box-Shaped slide ways. Mating surfaces are covered with special synthetic resin. The ball screws are forced lubricated. Telescoping steel covers protect the ways and screws from chips, coolant, and debris.

### Built-in high speed gantry type part loading system.

This very reliable loading system has a 1-Arm / 2-Grippers on the loading arm. It is also equipped with a 90 degree part turn-around device right above the loading spindles, and work-pushers in the package. Both sides of the part can be simultaneously machined utilizing this feature.



### Operation Panel



The tool posts on each slide are independently displayed on the central control panel. The swivel pendant arm make it easy for the operator to set up the machine.

### Pendant panel to be used for the part loading system.

Teaching and manual operation of the loading system are to be done on the same Control panel. The basic 8 pattern modes of the loading system are in the control unit. Selecting the pattern of the loading system mode can be easily selected and programmed.

### Designed with three totally isolated areas.

Upper : Part loading arm area. Middle : Part loading on the chucks. Bottom : Machining area.



### Part loading arm area

Shimada offers automated loading systems such as standard gantry and robotic systems, as well as customized solutions to fit your application.

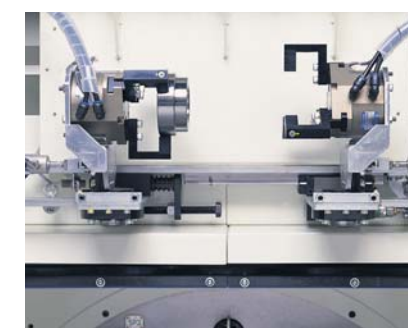

Work Reversing Unit

### Part loading on the chucks

Parts are loaded and un-loaded on upper two spindles while lower two spindles are machining parts.



Loading / Unloading

### Machining area

Lower two spindles work simultaneously machining either two identical parts or front and back of parts.



## ●Floor Plan

※As improvements, the specifications may be changed without notice.

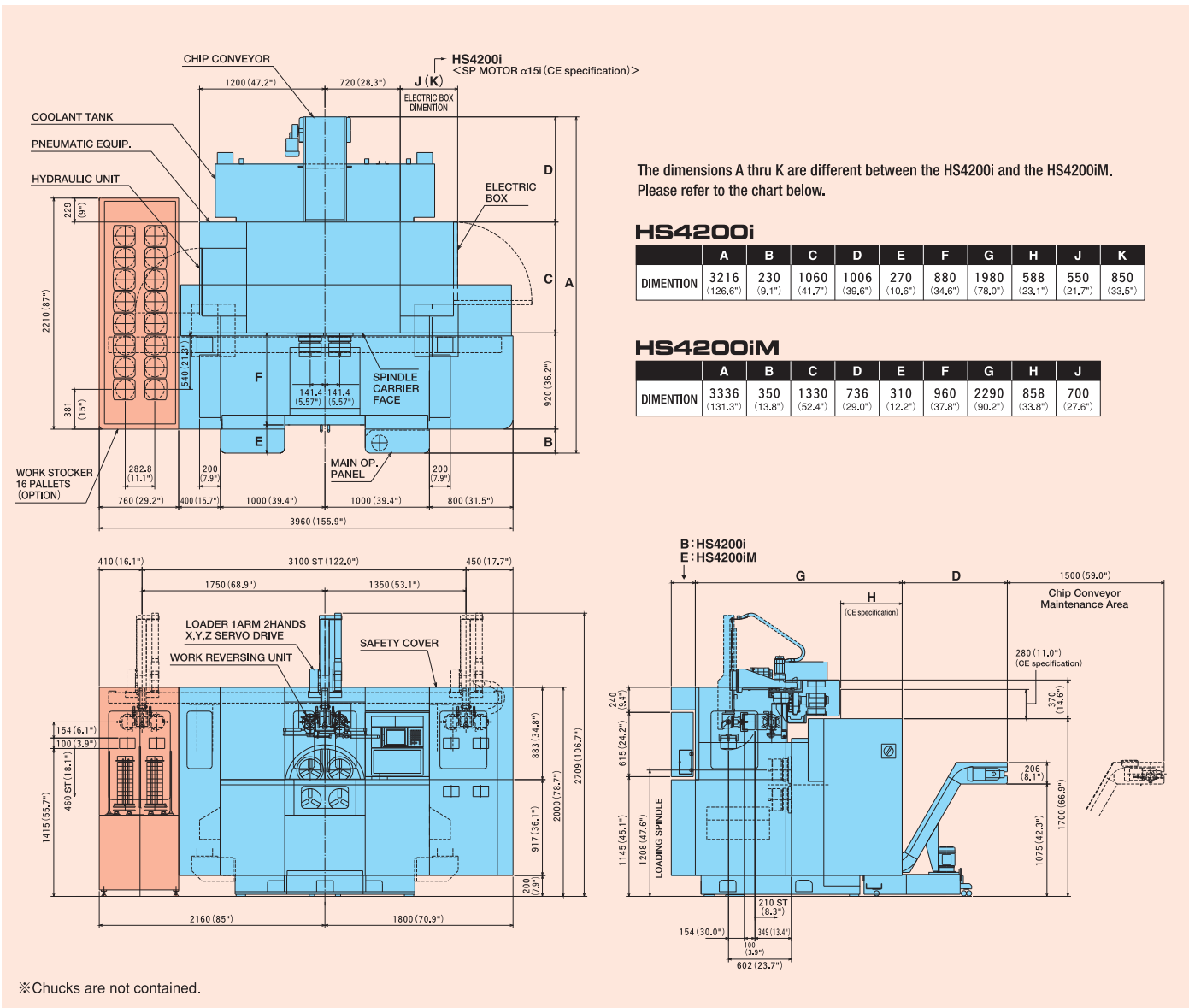

## ●Machine Specification

Chuck size	8"	X,Z axis Stroke	X: 160mm (6.3") Z: 250mm (9.8")	Main motor	11/15kW×2 (Const.30min.)
Number of spindle	4	X,Z axis Rapid traverse	X: 24m/min. (945IPM) Z: 30m/min. (1181IPM)	Turret station number	8st, OD: 4 ID: 4
Spindle nose	A2-6	Max. Turning dia.	φ200mm (7.8")	Size of O.D. tool	□25mm (□1")
Spindle speed range	45~4,500min <sup>-1</sup> Option 30~3,000min <sup>-1</sup> Option 50~5,000min <sup>-1</sup>	Max. Turning length	100mm (4")	Size of I.D. tool	φ40mm (φ1.5")
		Carrier Indexing Time	180°/1.5sec	CNC	FANUC/2 Path + Loader Control
				Machine weight	7500kg (with Loader)

## ●Loader Specification

Max. work size	φ150mm×100L (5.9"×3.9")	Stroke	X: 3100mm (122.0") Y: 450mm (17.7") Z: 210mm (8.3")	Stroke of hand	φ16 (3 Jaw Pneumatic)
Max. work weight	3kg×2 (6.6Lbs×2) *	Rapid traverse	X: 170m/min. (6693IPM) Y: 120m/min. (4724IPM) Z: 55m/min. (2165IPM)	Weight	500kg
Hand index	90°			Work Reversing Unit	

※If the workpiece weights more than 6.6 lbs, please discuss it with your representative, as the speed of the loading system may need to be reduced.

## ●CNC Specification

CNC	FANUC/2-Path	Least input increment	0.001mm, 0.001deg.	Least manual feed	0.1/0.01/0.001mm
Interpolation	Linear, Circular	Least command increment	X: 0.0005mm/p, Z: 0.001mm/p	Tool offset value	±999.999mm (16 Groups)
Controlled axes	2axes (X/Z) ×2	Max. program dimension	±99999.999mm	Back lash compensation	±9999 μm
Simultaneous controlled axes	2axes×2	Feed command	mm/rev. mm/min	Between Spindle Compensation function	Spindle offset
		Thread read command/F4	0.0001~500.0000mm/rev.		

Others

- Machine lock
- Block delete
- Error detect
- Single block
- Dry run
- Chamfering
- Constant surface speed control
- Decimal point programming
- Incremental feed
- Incremental tool offset
- Chamfering/corner rounding
- Nose radius compensation
- Tool wear & Geometry offset
- PMC Diagram display
- Canned cycle G90/92/94
- Multiple repetitive cycles
- Tool life management
- Alarm history display
- Graphic display
- Sequence number search
- Program number search
- Run hour display
- Stored stroke check
- Memory card input/output
- Reader punch inter fase (RS232C)

## ●Tooling System

### Standard Tooling System

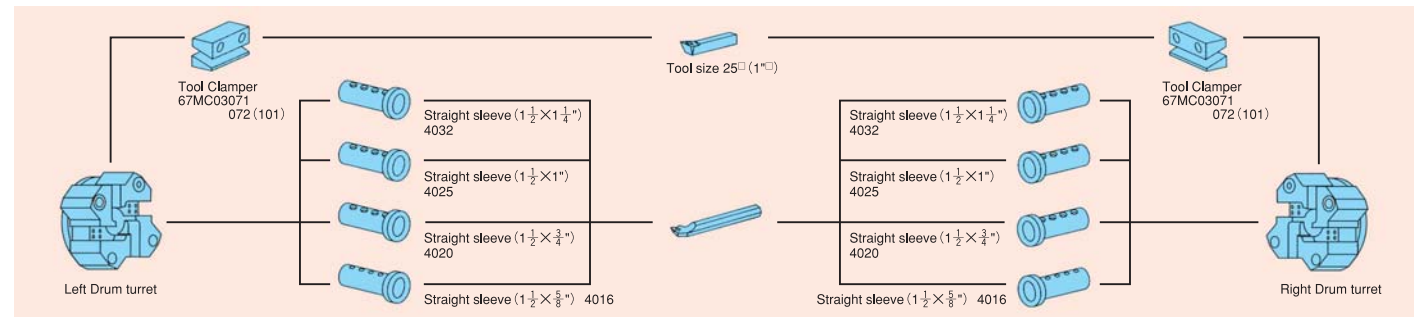

### HS4200iM/nM Tooling System

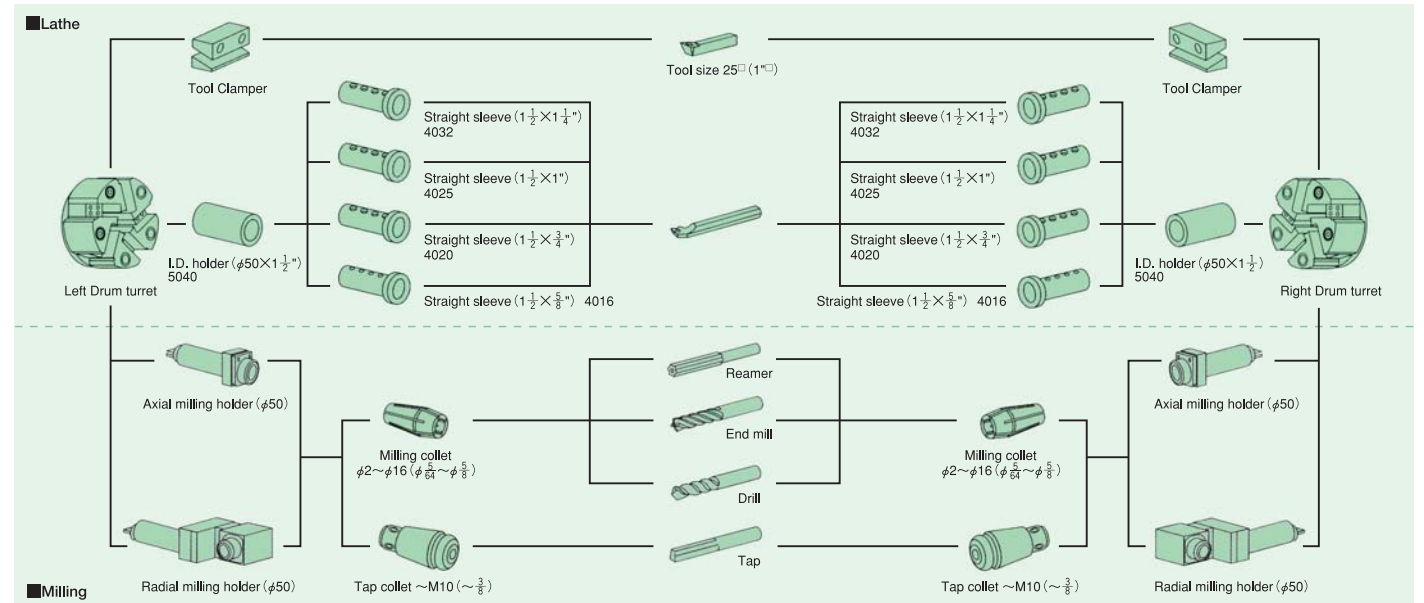

## ●8-Stations Drum Turret Tool interference diagram/Tooling stroke

### 8-St. Drum Turret

### 8-St. Drum Turret for both ID/OD tool on any of the stations. (Optional)

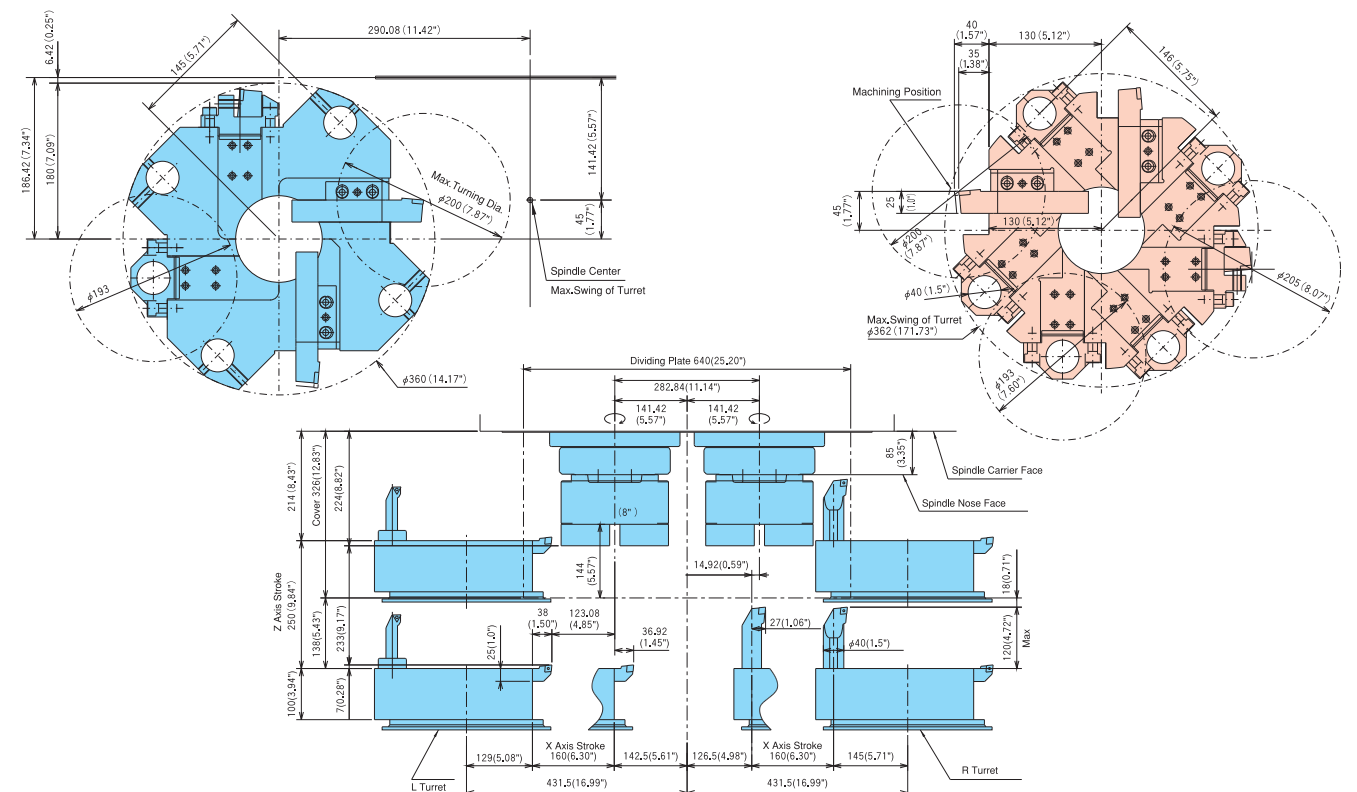

● Torque/Horse Power Charts (Independently driven spindles)

Spindle motor 11/15kW (Cont./30min.)

Spindle speed range 4,500min<sup>-1</sup>

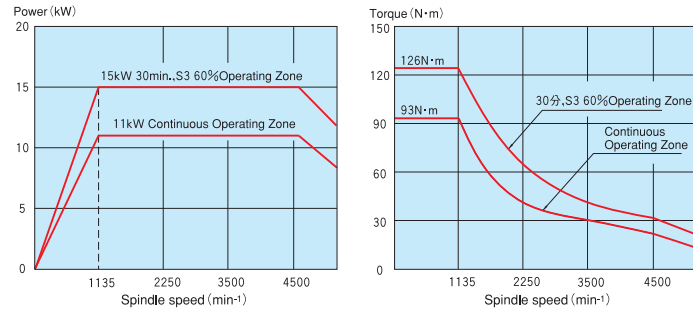

Option

Spindle speed range 3,000min<sup>-1</sup>

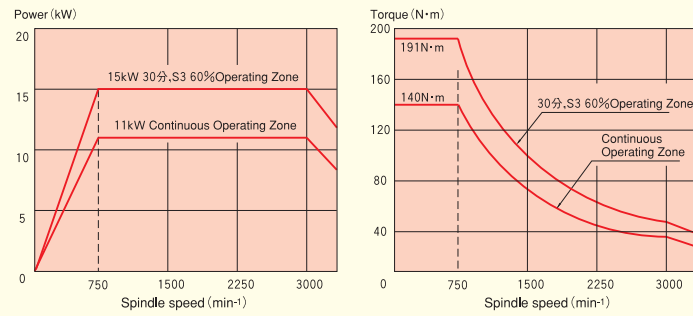

Option

Spindle speed range 5,000min<sup>-1</sup>

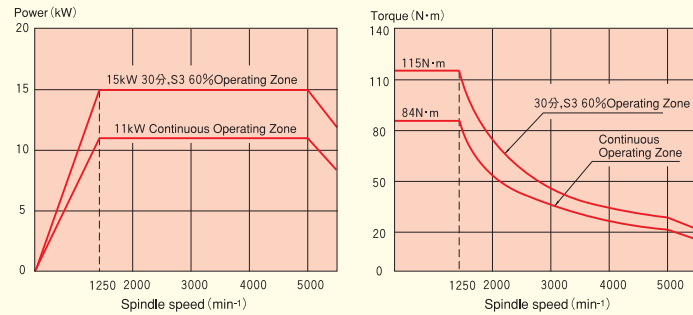

● Main Spindle & Bearing Construction

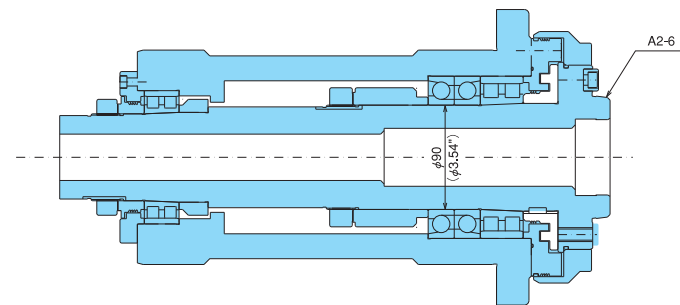

Grease enclosure type cartridge  
With spindle air purge

● The variety of Loader X-Axis strokes

● Stroke 3100 (122")

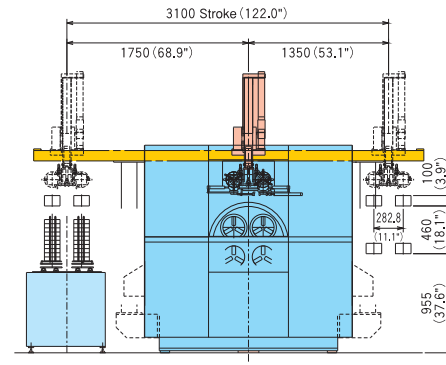

● Stroke 3100 (122") (Stroke-shift to the right side)

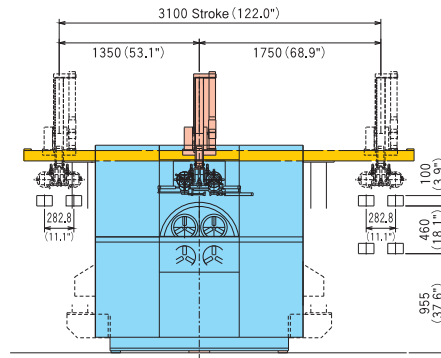

Option

● Extended type Stroke 3500 (137.8")

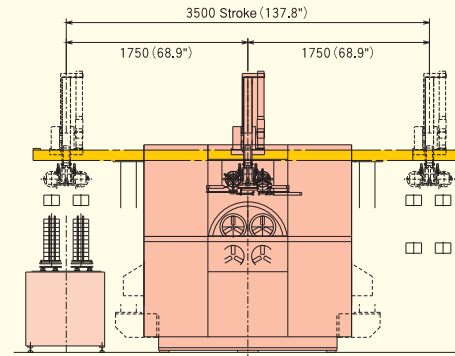

Option

● Extended type Stroke 4000 (157.5")

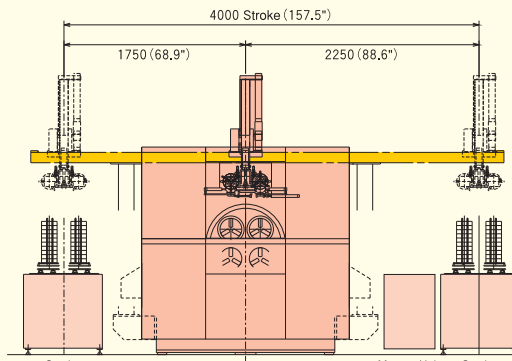

● Options

Max. spindle speed	3,000rpm, 5,000rpm
Special 8 station turrets	I.D. and O.D. tools fitted in all the stations. Please see page 6
Coolant through spindle	Available for two or four spindles, unable to be combined with work location air sensor.
Work location air sensor	Air pressure is adjustable by the pressure switch. Available for two or four spindles, unable to be combined with coolant through spindle.
Chip conveyor	Magnetic scraper type for cast iron Rolling drum filter type for aluminum
Extended X axis on loader	137.8" (3,500mm), 157.5" (4,000mm) Please see page 7
In and Out conveyors	Conveyor lengths 40" (1000mm), 59" (1500mm), other lengths are available upon request.
In-feed transfer conveyor	from work stocker Chute lengths 20" (500mm), 40" (1,000mm), other lengths are available upon request.
Spindle Orientation	for live milling applications and for loading parts that require orientation, such as irregular-shaped parts.

● Pallet Work Stocker



The rotary work stocker with 16 pallets can be stationed at the right and left sides of the machine. (Please see page 7)  
The light curtain at the work area assures safe operations.



O.D. Gripping  
Max. Work Dia. 150 (5.9")

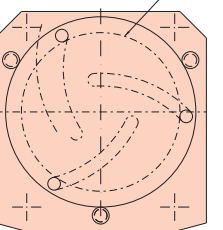

I.D. Gripping  
Max. Workpiece Dia. 180 (7.1")

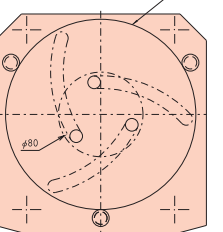

● Work Stocker Specifications

Number of Pallet	16
Work size	φ50~φ150mm (2"~5.9")
Max. work weight	40kg/pallet
Total work height	400mm (15.7")
Weight	430kg

● Silent Panel



The optional silent panel can reduce noise level.

Special specifications  
and designs are  
available upon request.

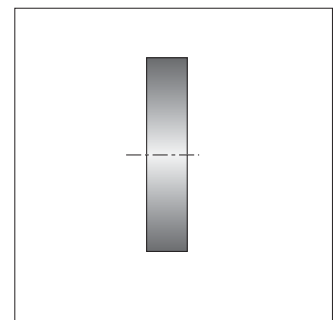
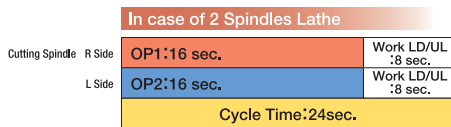
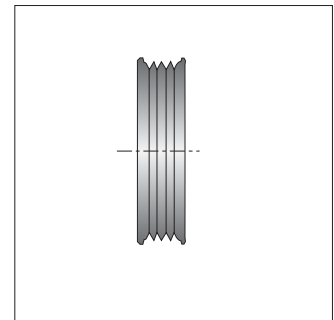
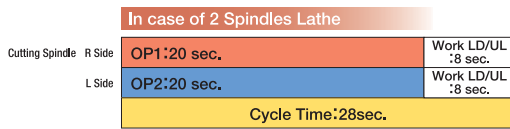
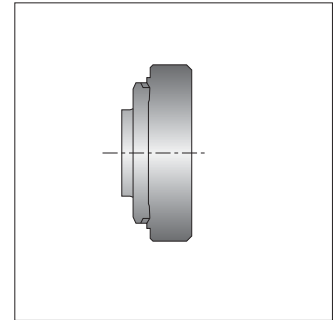
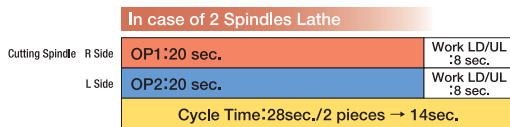
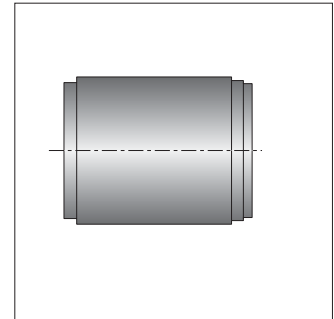
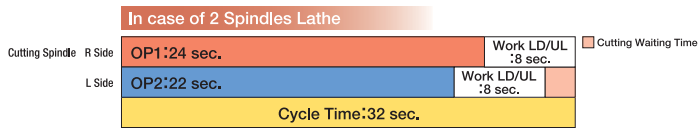

Two 2 Spindle Lathe Connection

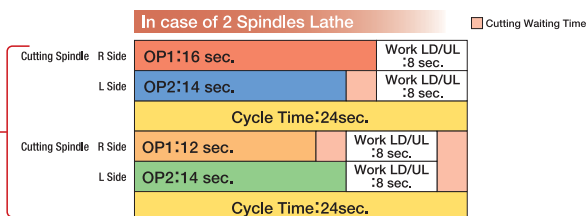



## ●Milling Function (HS4200iM/nM)



Spindle motor for live tool	AC2.2/3.7kw
Max. speed of live tool	4,000min <sup>-1</sup>
Torque of live tool	14.0 N·m
Least command increment	0.001 (deg)
Max. dia of live tool	Drill Mill φ16 · Tap M10
Number of tool	10St/Turret O.D.5, I.D.5
Size of O.D. tool	□25mm □1"
Size of I.D. tool	φ40mm (φ1.5")

※Maximum RPM of live tool varies by specification of live tool holders.

•Live tooling comes with 10 station turret with a capacity of up to five (5) live tools, to share the I.D. stations with I.D. tools, and five (5) O.D. tools.

## 10-St. Milling Turret/Tooling stroke

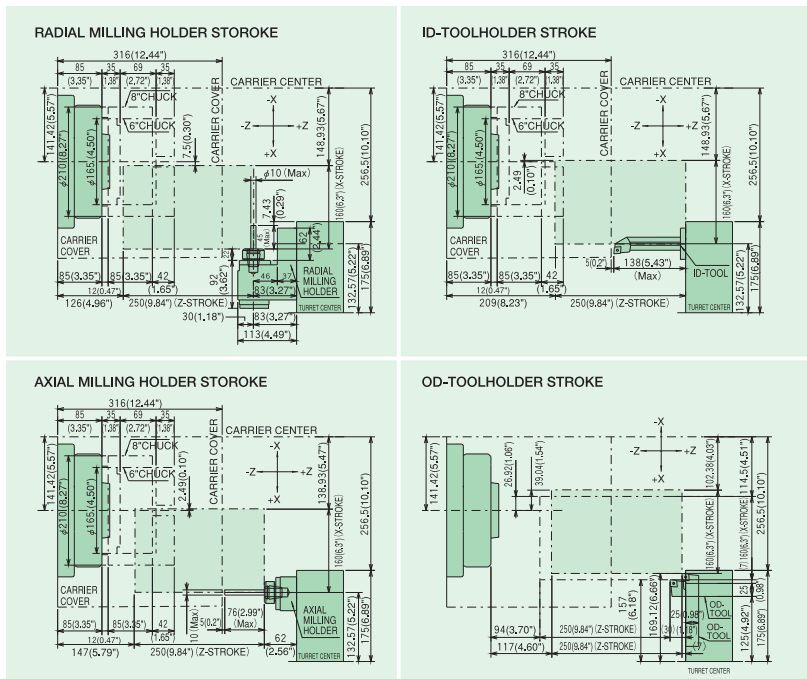
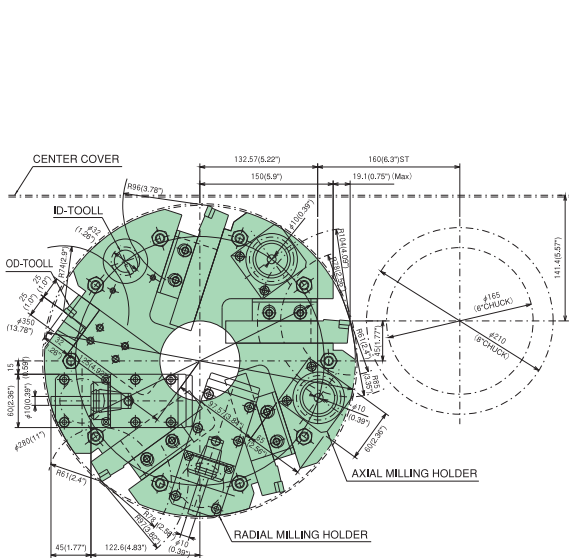

## ●FLOOR PLAN (Loader non-carrying machine·HS4200n/nM)

※Specifications are subject to change without notice.

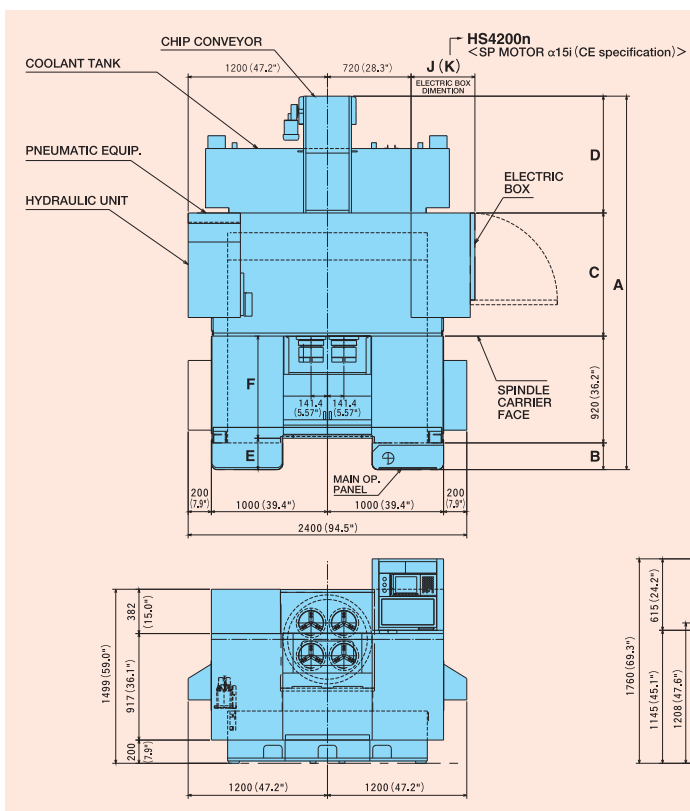

the dimensions A thru K are different between the HS4200n and the HS4200nM. Please refer to the chart below.

HS4200n										
DIMENSION	A	B	C	D	E	F	G	H	J	K
	3216	230	1060	1006	270	880	1980	588	550	850
	(126.6")	(9.1")	(41.7")	(39.6")	(10.6")	(34.6")	(78.0")	(23.1")	(21.7")	(33.5")

HS4200nM									
DIMENSION	A	B	C	D	E	F	G	H	J
	3336	350	1330	736	310	960	2290	858	700
	(131.3")	(13.8")	(52.4")	(29.0")	(12.2")	(37.8")	(90.2")	(33.8")	(27.6")

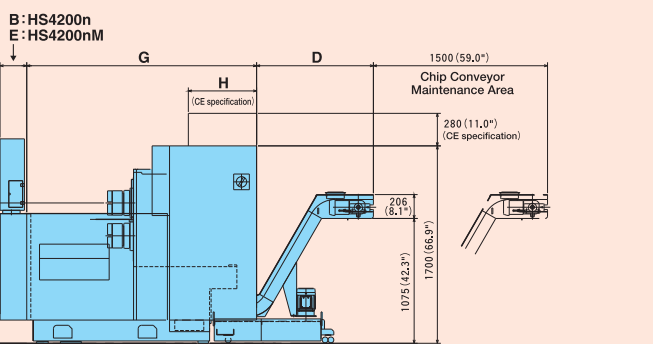

※Chucks are not contained.

## MACINING METHODS

### 1 AB/AB METHOD. Front and back side operation with one 180 degree carrier index.

Front side by OP1, part reversed during load/unload sequence, Back side by OP2. OP1 and OP2 are independently machined at the same time. AB/AB method most effective when the OP1 and OP2 cutting times are close or identical.

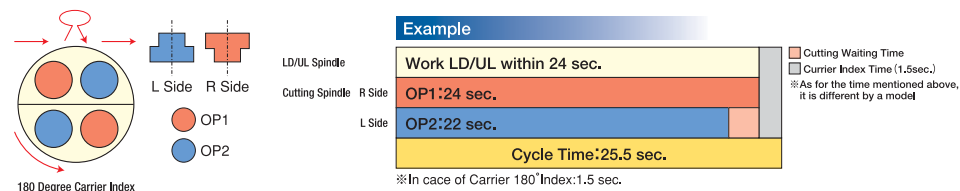

### 2 AA/AA METHOD. Twin single operation parts with one 180 degree carrier index.

Two single operation parts are loaded/unloaded and machined simultaneously. AA/AA method is applied when only machining one side.

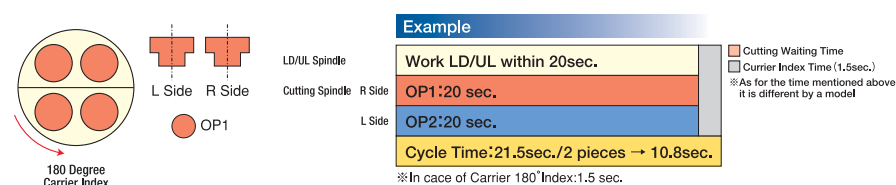

## EXCLUSIVE DESIGN CORRESPONDENCE

### 3 AA/BB METHOD. Twin front and back side operation with two 180 degree carrier indexes.

Two front sides machined simultaneously by OP1, both parts reversed during load/unload sequence, two back sides machined simultaneously by OP2. With this method two parts are completed every other carrier index. AA/BB method is effective if the OP1 and OP2 cutting times are unbalanced and sufficient tooling for both OPs can be mounted in each turret.

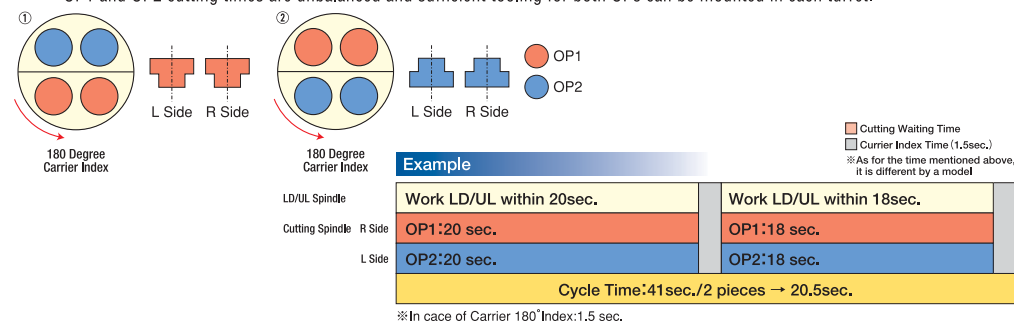

### 4 AA/A'A' METHOD. Split process of twin single operation parts with 90 degree carrier index.

The machining process is divided into OP1 (roughing) and OP2 (finishing) of one single operation part. AA/A'A' method is employed when the number of turret stations is insufficient.

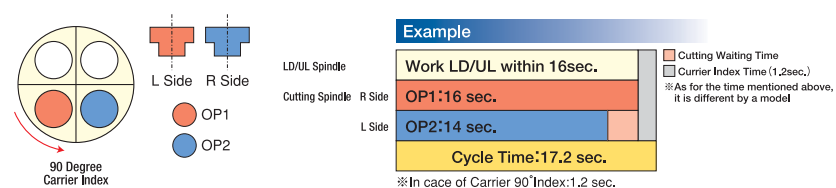

### 5 AB/CD METHOD. Multiple operations on one machine with two 180 degree carrier indexes.

The machining process is divided into four operations; OP1, OP2, OP3, and OP4. The AB/CD method provides one completed part every other carrier index and is effective for multi-process operations.

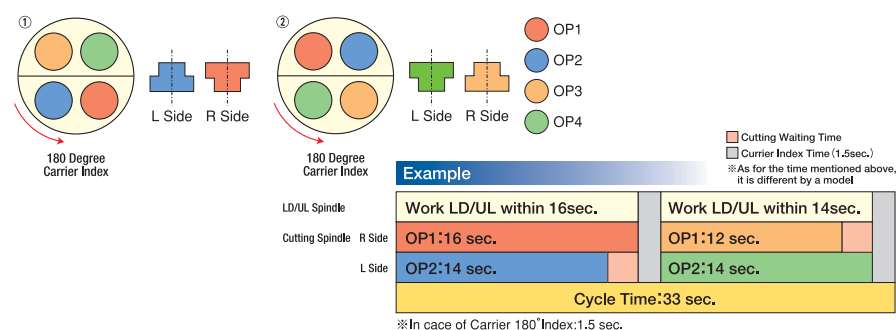

## PRODUCTIVE LATHES

- 1 Part Name
- 2 Material
- 3 Cycle Time

- 1 YORK
- 2 DSPHC-P
- 3 20.0sec./2piece

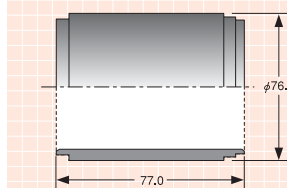

- 1 GEAR
- 2 ScR420H
- 3 27.5sec./piece

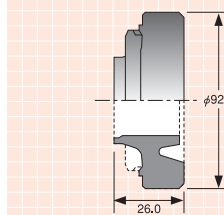

- 1 PULLY
- 2 FC250
- 3 110.0sec./piece

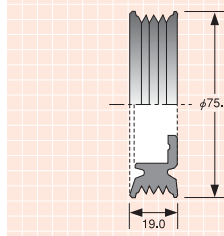

- 1 RING
- 2 S55C
- 3 40.0sec.

