

PALMARY PRODUCTS

- Centerless Grinder
- Cylindrical Grinder
- Internal Grinder
- Vertical Grinder
- Surface Grinder
- Special Purpose Grinder

www.grinding.com.tw

INTERNAL GRINDER

OIG CNC series

IG NC series



CNC SYSTEM SALES, INC.

R. Kent Baker
President

(317) 251-2770 Office
(317) 251-2888 Fax
(317) 431-7191 Cell
kbaker@cncsystemsales.com



PALMARY MACHINERY CO., LTD.
 No. 77, Gongye Rd., Dali Dist.
 Taichung City 41280, Taiwan.
 Tel: +886-4-2492-9799
 Fax: +886-4-2492-9499
 E-mail: palmary@grinding.com.tw



1709N1

PALMARY
 PALMARY MACHINERY CO., LTD.

**PRECISION
PERFECTION
EXCELLENCE**

**PURSUANCE OF
PERFECTION**

**EXTRAORDINARY DESIGN!
USER-FRIENDLY OPERATION!**

The new CNC internal Grinding Machine from PALMARY features optimal structural design, and an elegant appearance combined with advanced CNC control. The all new series will bring internal grinding technology into a new era. The structural parts of the machine are manufactured from high quality cast iron for deformation-free performance year after year. The entire machine is precision built throughout to guarantee the best possible grinding accuracy you can find anywhere.



- [OIG-200]
- ONE INTERNAL WHEEL SPINDLE
 - 2-AXIS CONTROL



Moving Distance of Workhead spindle

Distance between Centers

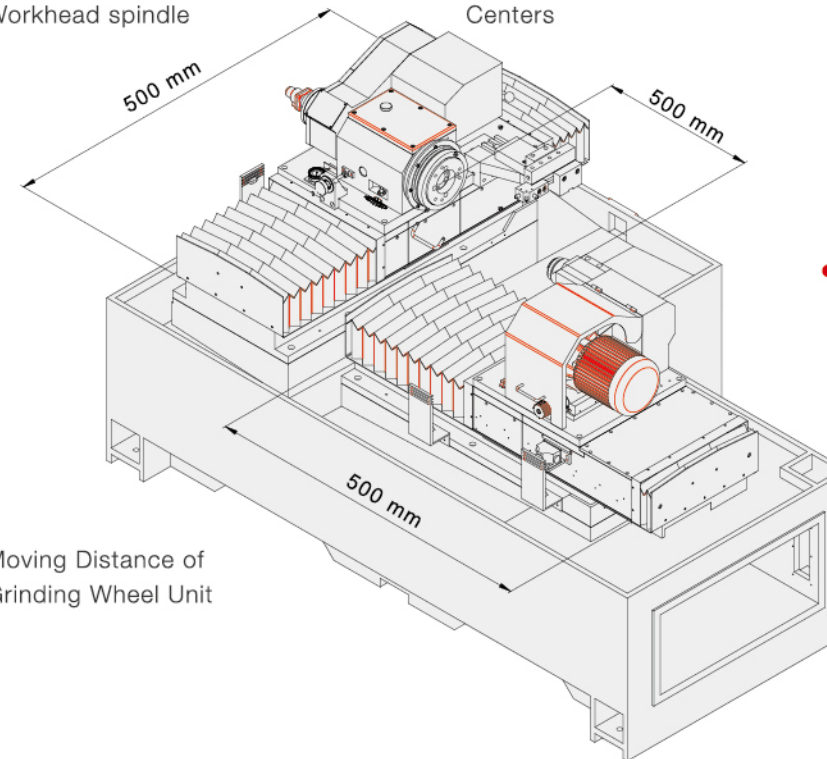

- RANGES OF THE MOVING PARTS

Moving Distance of Grinding Wheel Unit

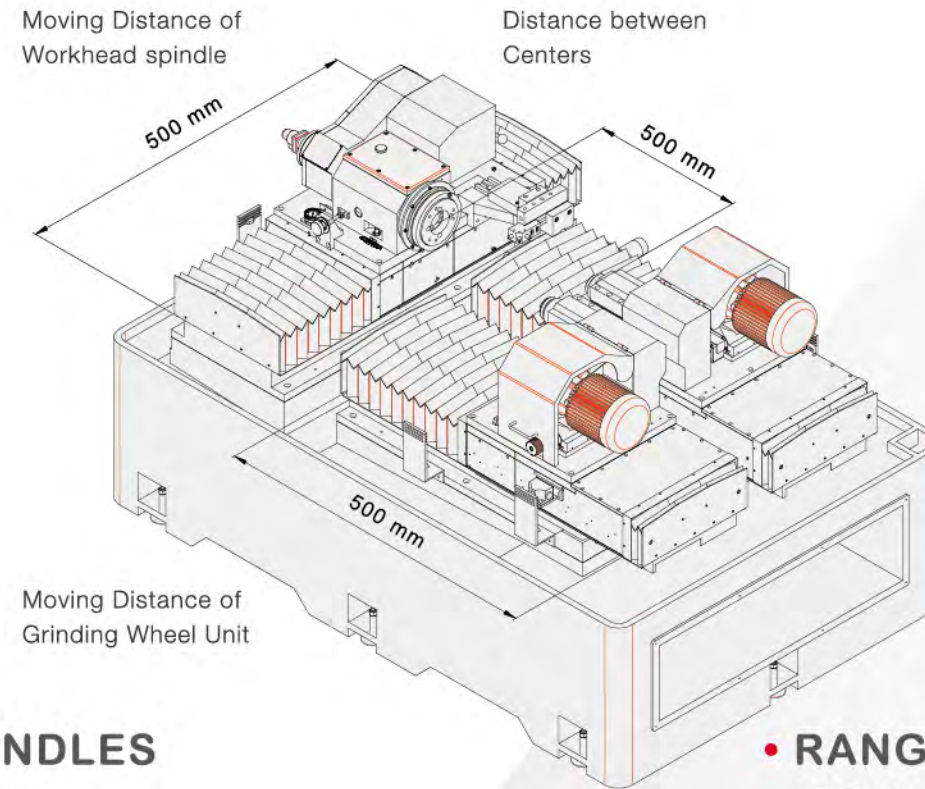

COMPLETE GRINDING SOLUTION IS HIGHLY EXPERIENCED AND OFFERS SERVICES TO ALL MAJOR INDUSTRIES

- [OIG-200D] • TWO INTERNAL WHEEL SPINDLES
- 3-AXIS CONTROL

- RANGES OF THE MOVING PARTS

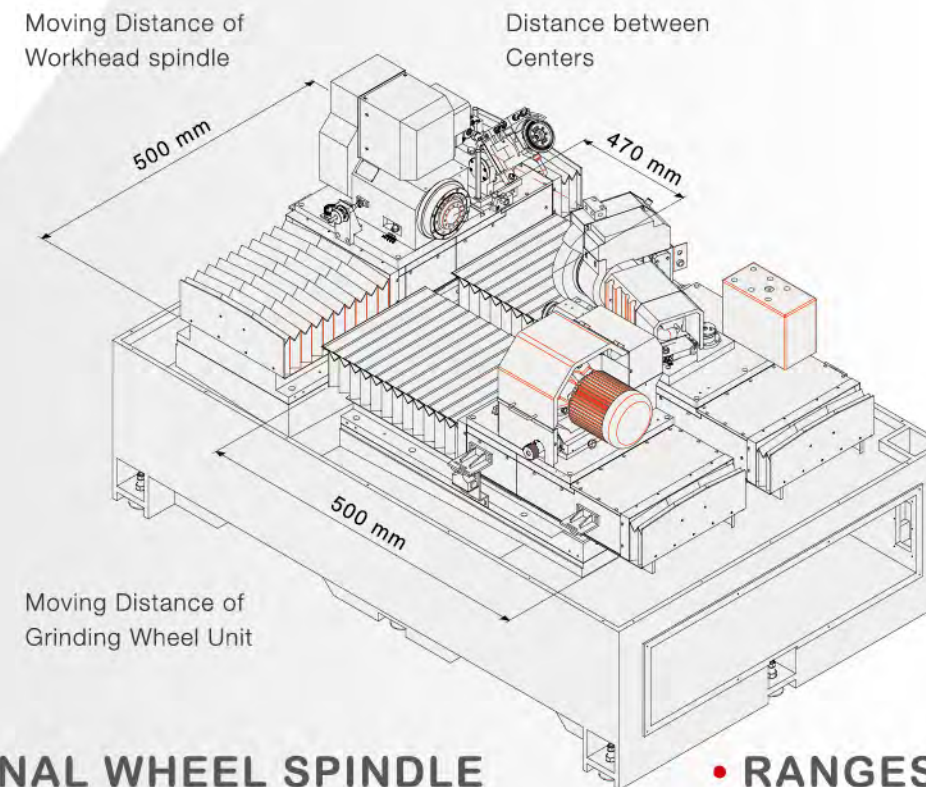

- [OIG-200DE] • ONE INTERNAL & ONE EXTERNAL WHEEL SPINDLE
- 3-AXIS CONTROL

- RANGES OF THE MOVING PARTS

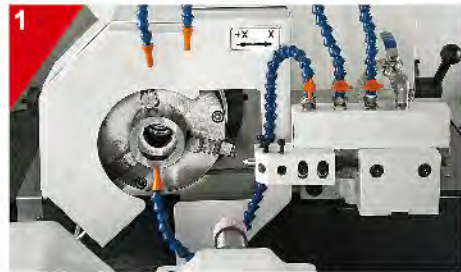

GEAR FIXTURE (OPTIONAL)

- A fixture specially designed for fast and convenient gear loading and unloading.
- Three-point clamping design.



WHEEL HEAD SLIDE

- Providing a selection of automatic or manual feed modes.
- Dressing amount is set through the conversational human machine interfacing controller. Minimum setting unit is 0.001 mm.
- Wheel dressing amount is set as desired.
- Dressing position can be memorized.



AUTOMATIC BELT TENSION ADJUSTMENT

Automatic belt tensioning is made by means motor self-weight and eccentric shaft, assuring full power transmission. This also avoids affection on grinding quality due to belt loosening. Frequency inverted motor permits variable speed changes to suit various workpiece materials.

OUTSTANDING FEATURES

- The entire machine is ergonomically designed for user-friendly operation. The machine bed is manufactured from high quality cast iron, specially heat treated and precision machined to ensure deformation-free performance, year after year.
- A three axes CNC grinder consists of X, Z and Y-axis, with the two grinding wheel spindles, the machine is capable of grinding small hole, end face and outside diameter at one time that is suitable for parts requiring high concentricity accuracy.
- Suitable for grinding, internal straight hole, end face, internal chamfering angle, internal circular angle, internal taper and internal step, etc.
- To meet mass production requirements, automatic loading and unloading equipment is available to provide a fully automatic operation.
- The slides move on roller type linear guideways for increasing smoothness & stable movement.
- Flexible grinding spindle combination and the use of oversized grinding wheel allows for grinding outside diameter or end face. Powerful complex functions and custom-made is available.
- All axes support each other to allow multiple processes to be accomplished in one cycle, saving repetitive workpiece setup and handling time.
- Basic teach-in grinding programs enable operator to fill the defined parameters into columns for setting various grinding conditions. It also allows for setting automatic dressing compensation for increasing efficiency.
- The feed axis is equipped with optical scale to upgrade positioning accuracy.
- Bearing type work spindle can be used together with various jigs.

FANUC CNC CONTROLLER

CNC CONTROL SYSTEM

- Program storage 160 M
- Registered program
- Program number search
- Program protection
- Background editing
- Bilingual display: English / Chinese
- Display of spindle speed, T code, workpiece
- Quantity and processing time on screen
- Actual speed display
- External key input
- External message
- I/O device control
- MDI operation
- Reset
- Dry run
- Single block
- Program protection
- Emergency stop
- Status display
- Incremental pulse coder interface
- Automatic coordinates setting
- Workpiece coordinates setting
- Z axis simultaneous controlability
- Least input increment: 0.001mm
- Least command increment: 0.001mm
- Rapid traverse override: 0, 25, 50, 100
- Automatic acceleration / deceleration
- Linear acceleration / deceleration after cutting
- Feedrate vverride 0 to 150%
- Positioning
- Linear interpolation
- Circular interpolation
- Latest digital.
- Easy to operate.
- Excellent for grinding applications
- Convenient editing.
- Complete software package
- Reference position return
- Rerence position return check
- Program combine
- Special G code input
- Programming input of offset data
- Custom Macro B
- Inch/Metric conversion
- Tool nose radius compensation
- Canned cycles for grinding
- X axis diameter / radius command
- Counter input of offset value
- Radius designation on Arc
- External data input/output
- Manual handle feed - I unit
- Manual handle feed rate adjustable
- Dwell (per sec)
- High-speed skip function
- External deceleration
- Position signal output
- Battery alarm output
- Backlash compensation
- Stored pitch error compensation
- Clock function
- EIA/ISO automatic recognition
- Multi-step skip
- Miscellaneous function
- 9" CRT/MDI high-resolution Monochrome screen
- Program erase function
- Program copy function
- Self-diagnosis function
- 32 pairs tool offset memory
- Dressing compensation
- Tool geometry/wear offset
- Simple tool life management
- Custom Macro



CONTROL CIRCUIT MEETS EUROPEAN STANDARDS

- The control circuit consists of high quality electronic components, featuring dependable control performance and long service life.
- The electric cabinet is equipped with a heat exchanger, providing a constant temperature for the control circuit and maximum stability of control performance.

CONTROL SYSTEM

INTERNAL GRINDING SPINDLE for OIG CNC series IG NC series

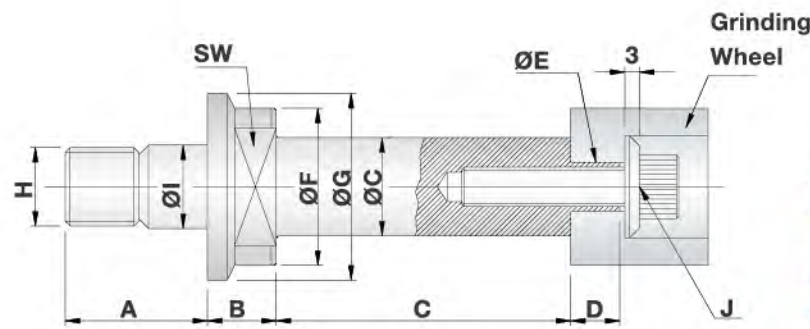

NOTE:

- The appropriate ratio of grinding hole diameter to length is 1:3.
- Max. grinding length 200 mm for CNC series.
- Max. grinding length 150 mm for NC series.

INTERNAL GRINDING SPINDLE SPEED RANGE

Grinding Dia.	Grease Type	A	B	C	D	E	F	G	H	I	J	SW	Oil Mist Type
Ø65 ~ Ø150	8,000 r.p.m.	42	16	Ø40 x 100 Ø40 x 85 Ø40 x 55	12	Ø12	Ø50	Ø58	M26 x 2P	Ø28	M8 x 1.25P	41	
Ø40 ~ Ø80	10,000 r.p.m.	29	14	Ø30 x 90 Ø20 x 60 Ø30 x 90	10	Ø10	Ø32	Ø38	M16 x 1.5P	Ø17	M8 x 1.25P	24	
Ø35 ~ Ø70	15,000 r.p.m.	29	14	Ø25 x 70 Ø20 x 60 Ø24 x 80	10	Ø10	Ø32	Ø38	M16 x 1.5P	Ø17	M8 x 1.25P	24	
Ø24 ~ Ø40	20,000 r.p.m.	28	11	Ø20 x 60 Ø16 x 40 Ø16 x 40	8	Ø8	Ø26	Ø32	M14 x 1.5P	Ø15	M6 x 1.0P	19	
Ø15 ~ Ø25	30,000 r.p.m.	21	9	Ø13 x 30 Ø10 x 25 Ø12 x 35	6	Ø6	Ø21	Ø26	M10 x 1.5P	Ø10.5	M4 x 0.7P	17	30,000 r.p.m.
Ø12 ~ Ø16	40,000 r.p.m.	20	8	Ø10 x 30 Ø8 x 25 Ø8 x 30	x	x	Ø18	Ø23	M8 x 1.25P	Ø8.5	M4 x 0.7P	14	40,000 r.p.m.
Ø9 ~ Ø13	50,000 r.p.m.	18	7	Ø7 x 25 Ø6 x 20	x	x	Ø15	Ø20	M7 x 1P	Ø7.5	M4 x 0.7P	11	50,000 r.p.m.

GRINDING EXAMPLE

INTERNAL BREATHING HOLE	TWO-STEP STRAIGHT HOLES	INTERNAL BREATHING HOLE + OUTER END FACE (GEAR)	INTERNAL RECESS HOLE + INTERNAL END FACE	GRINDING WHEEL DRESSING
INTERNAL TAPER HOLE	INTERNAL RECESS HOLE + INTERNAL CHAMFERING ANGLE	INTERNAL RADIUS (R DRESSER-SPECIAL ACCESSORY)	INTERNAL BREATHING HOLE + INTERNAL CIRCULAR ANGLE	GRINDING WHEEL END FACE DRESSING

WORKING EXAMPLE

MODEL	BUSH
Material	SCM415(JIS)
Dimensions	Ø82x35xØ30mm
Stock removal	0.25mm/60sec.
Hardness HRC	HRC 55 \pm 2°
Tolerance	5 μ m
Spindle speed	20,000 r.p.m.
Roundness	2 μ m
Cylindricity	3 μ m

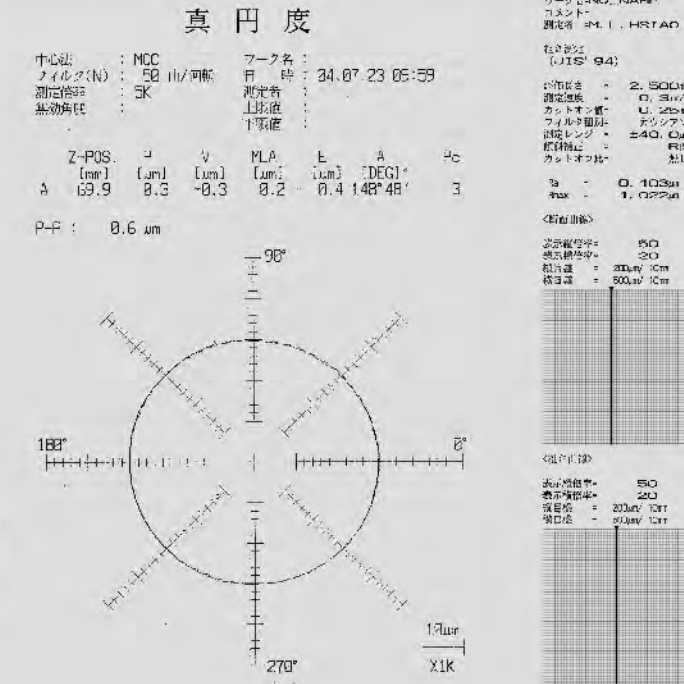

OIG-200 / 200D

MODEL	OIG-200	OIG-200D
Capacity	Internal grinding range (I.D.: length= 1.3)	Ø6~200 mm
	Max. workpiece length	200 mm
	Inside chuck guard swivel	Ø280 mm
Internal Wheel Spindle	Spindle outer diameter	Ø90 m/min.
	Linear velocity	33 m/s
	Spindle speed	10000~50000 r.p.m.
Table	Max. table traverse	500 mm
	Max. table feed speed Z axis	5 m/min.
	Spindle speed	0~800 r.p.m.
	X axis feed speed	5 m/min.
Work Spindle	X axis minimum travel unit	0.001 mm
	Y axis minimum travel unit	-
	Z axis minimum travel unit	0.001 mm
	Workhead swivel	Forward 8°~Backward 7° (manual)
	Workhead motor	1 HP,4 P (Stepless variable frequency)
	Grinding wheel motor	2 HP,2 P (Stepless variable frequency)
	Coolant pump motor	1/8 HP,4 P
Motor	X axis servo motor	1.8 kw
	Y axis servo motor	-
	Z axis servo motor	1.8 kw
Controller		FANUC
Machine Weight	Net weight	4700 kg
		5700 kg

OIG-200DE

MODEL	OIG-200DE
Capacity	Max. external grinding diameter
	Max. internal grinding diameter (I.D.: length= 1.3)
	Max. workpiece length
	Inside chuck guard swivel
Internal Wheel Spindle (Z axis)	Spindle outer diameter
	Linear velocity
	Spindle speed
External Wheel Spindle (Y axis)	OD x Width x ID
	Linear velocity
	Spindle speed
Table	Max. table traverse
	Max. table feed
	Min. setting unit
	Swivel
Work Spindle	Speed
	Max. load (incl. chuck device)
	Min. setting unit
	Z axis wheel spindle motor
	Y axis wheel spindle motor
	Work spindle motor
	B-axis swivel device
Motor	X axis infeed table motor
	Z axis infeed table motor
	Y axis infeed table motor
	Hydraulic pump motor
	Coolant pump motor
Controller	
Machine Weight	Net weight

• The mentioned specifications & dimensions are subject to change without notice.

MACHINE DIMENSIONS

[OIG-200]

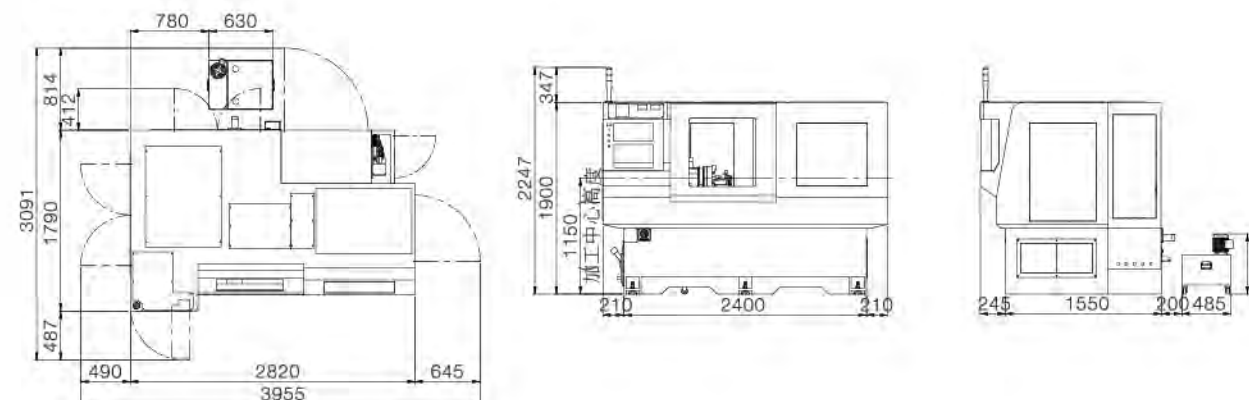

[OIG-200D / 200DE]

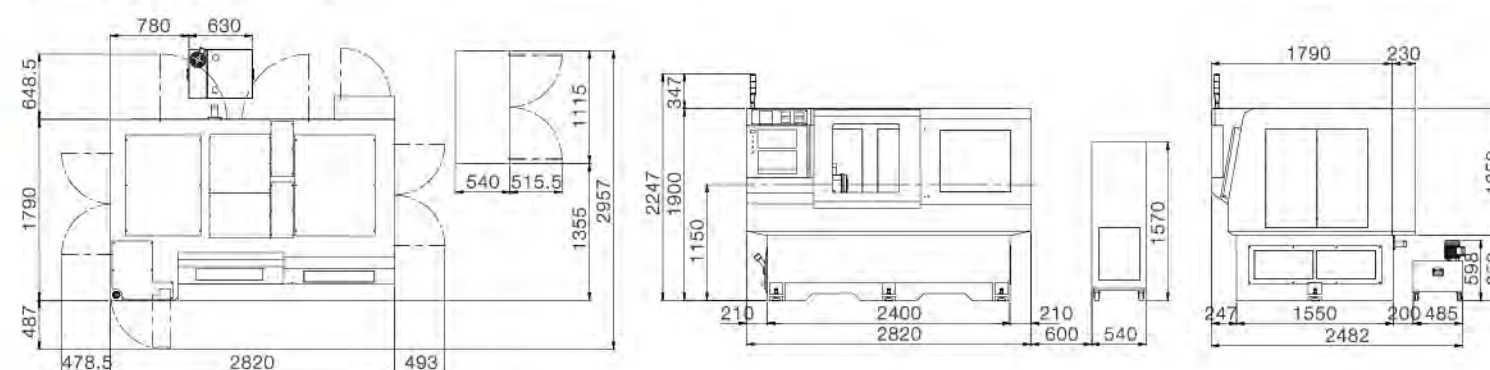

STANDARD ACCESSORIES

- Hydraulic system
- Coolant system
- Diamond dresser
- Fully enclosed splash guard
- Belt tension auto. adjustment
- Leveling pad
- Tools & tool box
- Grinding wheel spindle (alternative of 10000~30000 r.p.m.)
- Linear scale (X-axis)
- CNC controller

OPTIONAL ACCESSORIES

- Hydraulic 3-jaw chuck
- 3-jaw scroll chuck
- Magnetic coolant separator
- Paper filter
- Quick fixtures for gears
- Wheelhead oil lubricator
- Spare G.W. spindle
- Rotary dresser for CBN wheel
- Soft jaw machining device
- Gap control
- Oil mist collector

**MACHINE
DIMENSIONS**

MAXIMUM OPERATIONAL CONVENIENCE

PALMARY technical breakthroughs - the NC series internal grinding machines - are designed and engineered according to the highest standards. Great attention is paid to every detail of the entire machine. This fully reflects PALMARY's state-of-the-art manufacturing techniques. In addition, the NC series are equipped with a conversational operation interfacing control that makes your internal grinding easier and more accurate.

ADVANCED NC CONTROL

- The NC controller employs conversational operational interface. It applies words or graphics to replace the conventional lamp indication for added operational convenience.
- Increased control functions and easy change assure maximum operational convenience and flexibility.
- Trouble history records combined with troubleshooting instructions greatly upgrade servicing efficiency and quality.
- Fully digitized machining for upgrading machining accuracy, establishing standardization and ensuring product quality.

[IG-150-NC]



[IG-150-2NC]

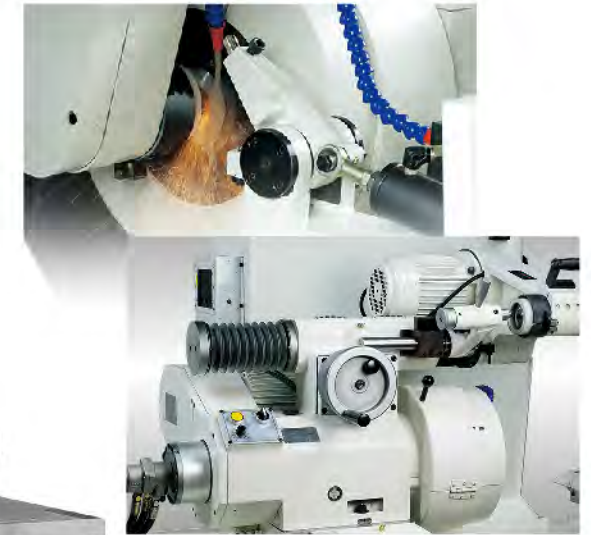

FACE GRINDING ATTACHMENT (OPTIONAL)

- Upon request, the machine is available to equip with a face grinding attachment to allow internal grinding and face grinding operations to be accomplished at one time. This assures outstanding perpendicularity accuracy while enormously upgrading efficiency.
- The face grinding attachment accommodates a common grinding wheel or a CBN grinding wheel (optional).
- Equipped with manual dressing device.

OUTSTADING FEATURES

1. The entire machine is ergonomically designed for user-friendly operation. The machine bed is manufactured from high quality cast iron, specially heat treated and precision machined to ensure deformation-free performance, year after year.
2. All slideways are lubricated by the static pressure automatic lubrication system, thereby providing extremely smooth movement and maximum wear resistance.
3. All the grinding motions - from rough grinding, dressing, finish grinding to spark out - are fully automatically operated. This provides high accuracy, convenient operation and greatly upgrades productivity. Also, it is excellent for mass production as well as small quantity, flexible workpiece grinding.
4. The workhead spindle runs on a high precision roller bearing featuring high accuracy, high rigidity and silent running. The workhead can be swiveled at clockwise 7° ~anticlockwise 8° , allowing for grinding tapered workpieces.
5. Precision ball screw combined with servomotor drive provide variable feed speed change.
6. The servomotor features compact construction, superior torque output, fast speed response, high accuracy and stability.
7. The slide reciprocating movement is driven by a hydraulic system, providing variable speed change and superior stability.
8. NC controlled automatic dressing with compensation.
 - In case a diamond or CBN grinding wheel is applied, a selection of no dressing is available.
 - For hard-to-grind parts, a multiple dressing mode can be selected to ensure the desired grinding quality.
9. To meet mass production requirements, automatic loading and unloading equipment is available to provide a fully automatic operation.

INTERNATIONALLY RECOGNIZED!

PALMARY'S NC INTERNAL GRINDING MACHINE

PALMARY technical breakthroughs - the NC series internal grinding machines - are designed and engineered according to the highest standards. Great attention is paid to every detail of the entire machine. This fully reflects PALMARY's state-of-the-art manufacturing techniques. In addition, the NC series are equipped with a conversational operation interfacing control that makes your internal grinding easier and more accurate.

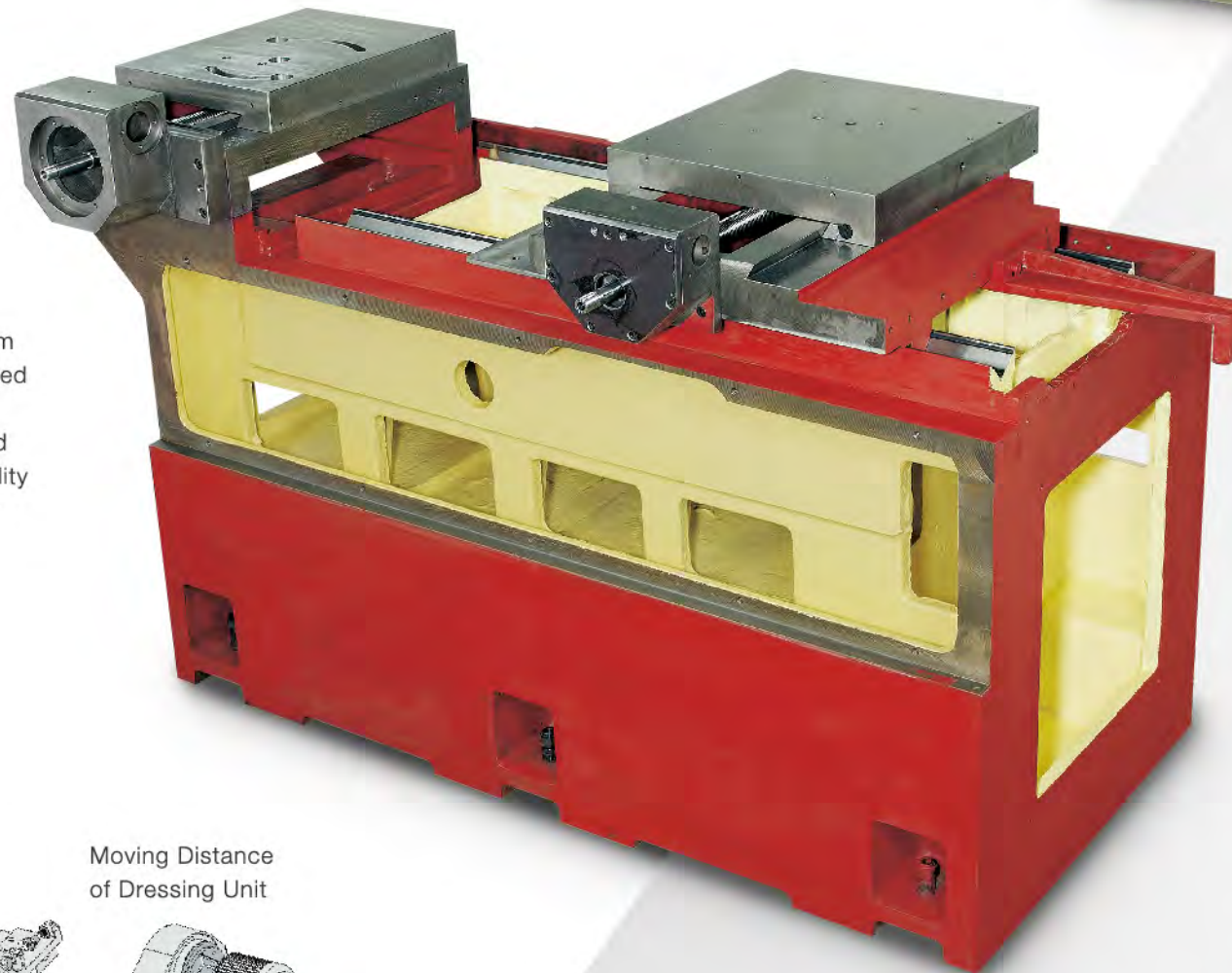

RIGID MACHINE STRUCTURE

- The machine structure is manufactured from high quality Meehanite cast iron, heat treated and stress relieved before machining.
- Slideways are high frequency hardened and precision ground. Maximum material stability for deformation-free and outstanding wear resistance.

RANGES OF THE MOVING PARTS

Moving Distance of
Workhead Spindle

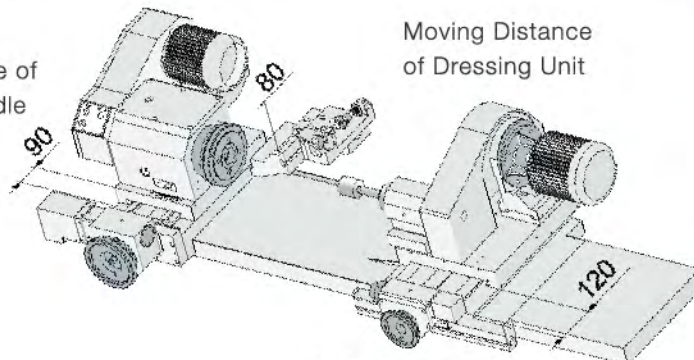

Moving Distance
of Dressing Unit

Moving Distance of
Grinding Wheel Unit



HIGH PERFORMANCE CONTROL CIRCUIT

- The control circuit, which consists of high quality electronic components, meets safety regulations and assures maximum control performance dependability.
- The control box is equipped with a heat exchanger to ensure constant temperature in the control box, and is also dust-proof.

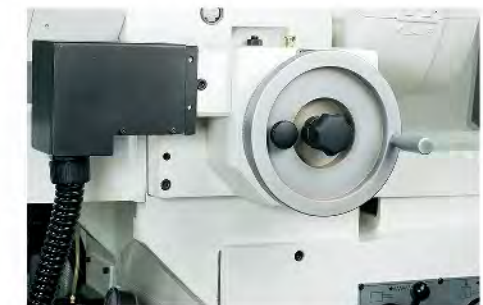

WORK HEAD SLIDE

- Employs Japan Mitsubishi servomotor for feed drive.
- The conversational control provides variable speed setting and feed setting.



WHEEL HEAD SLIDE

- Providing a selection of automatic or manual feed modes.
- Dressing amount is set through the conversational human machine interfacing controller. Minimum setting unit is 0.001 mm.
- Wheel dressing amount is set as desired.
- Dressing position can be memorized.



AUTOMATIC BELT TENSION ADJUSTMENT

- Belt tension is automatically controlled by the motor weight to ensure full power transmission at all times while avoiding belt loosening that can affect grinding quality.



GRINDING EXAMPLE

- a Grinding wheel rapid approach
- b+c Rough grinding
- d Rough grinding pause
- e Compensation & dressing process
- f+g Finish grinding start > Finish grinding pause
- h Stop grinding > Workpiece retract > Grinding wheel move to right

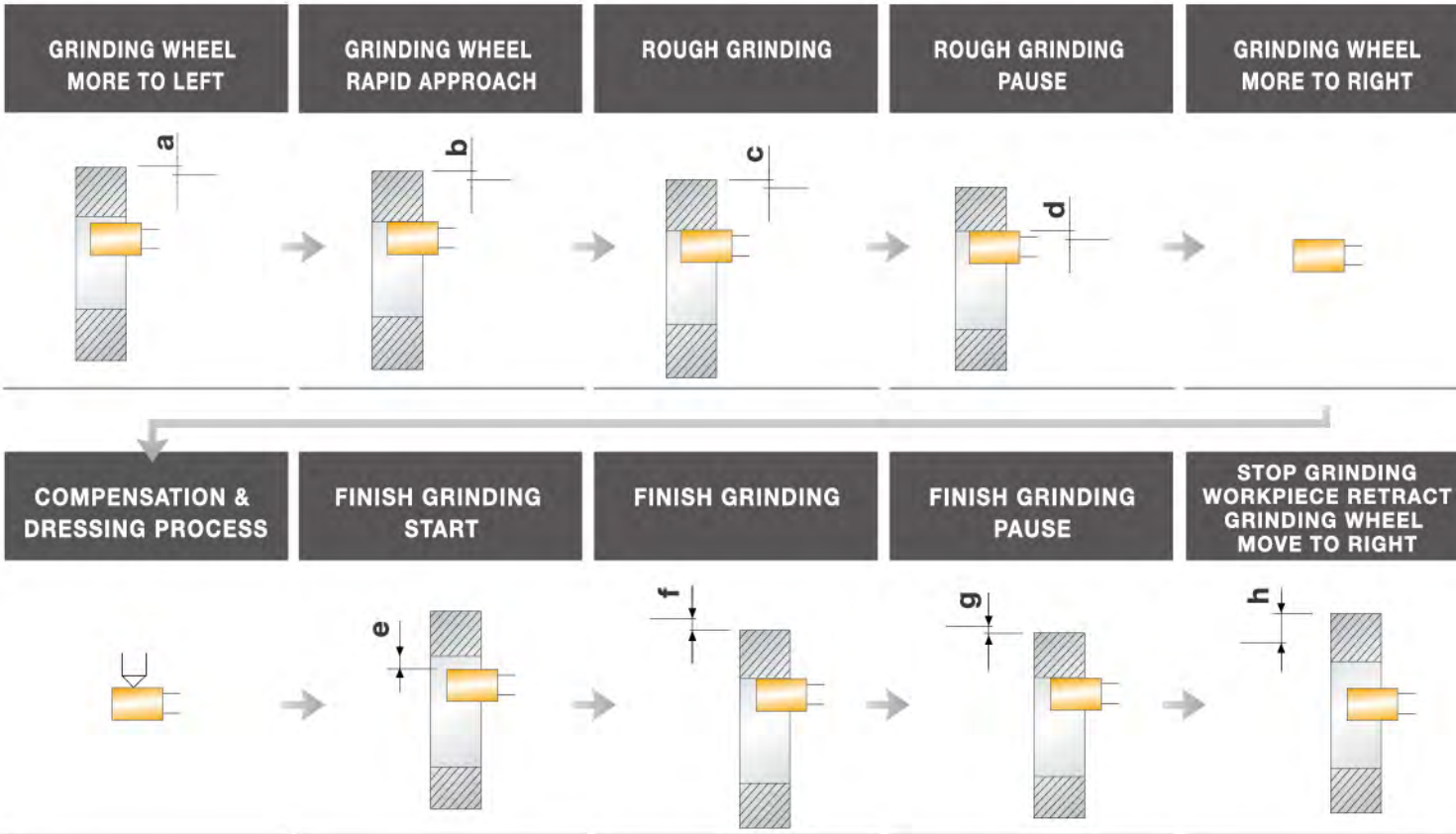

WORKING EXAMPLE

MODEL	BUSH
Material	SCM415(JIS)
Dimensions	Ø82x35xØ30mm
Stock removal	0.25mm/60sec.
Hardness HRC	HRC 55±2°
Tolerance	5 µm
Spindle speed	20,000 r.p.m.
Roundness	2 µm
Cylindricity	3 µm

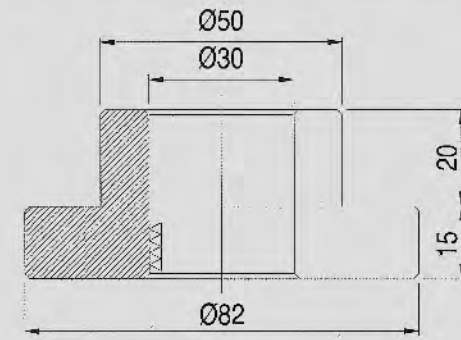

真円度 (Circularity)

ワーク名 : 04.07.23 05:59

Z-PCS [mm] P [µm] V [µm] MLA [µm] E [µm] A [DEG] Fc

A 69.9 0.3 -0.3 0.2 2.4 148°48'

P-P : 0.6 µm



IG-150-NC / 150-2NC

MODEL	IG-150-NC	IG-150-2NC	
Capacity	Internal grinding range (I.D.: length= 1.3)	6~150 mm	
	Max. workpiece length	150 mm	
	Workhead cover swivelling dia.	280 mm	
Work Spindle	Max. table traverse	540 mm	400 mm
	Max. table feeding speed Z axis	7.2 m/min. (hydraulic /1 axis)	10 m/min. (servomotor)
	Spindle speed	0~550 r.p.m.	
	Max. X axis feed speed	50 mm/min.	
	X axis minimum travel unit	0.001 mm	
	Z axis minimum travel unit	0.001 mm	
	Workhead swivel	Clockwise 7°~Anticlockwise 8°	
Tank	Hydraulic oil tank	60 L	
	Workhead motor	1 HP, 4P	
Motor	Hydraulic pump	2 HP, 4P	
	Grinding wheel motor	2 HP, 2P	
	Cooling system motor	1/8 HP, 2P	
	Workhead slide feeding motor	400 W	
Machine Weight	Net weight	2100 kg	2250 kg

• The mentioned specifications & dimensions are subject to change without notice.

MACHINE DIMENSIONS

[IG-150-NC]

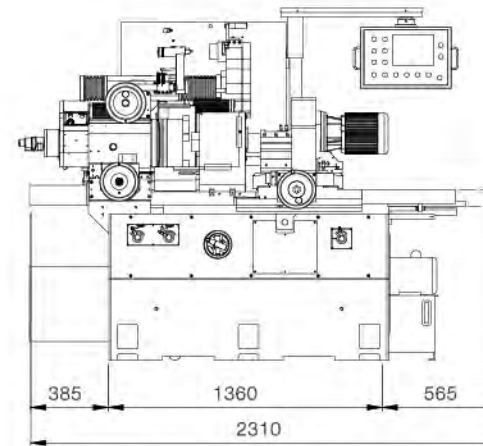
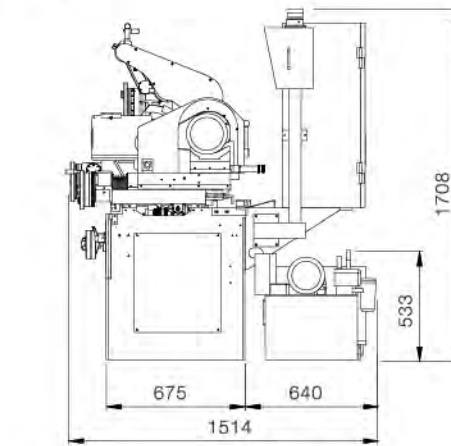

[IG-150-2NC]

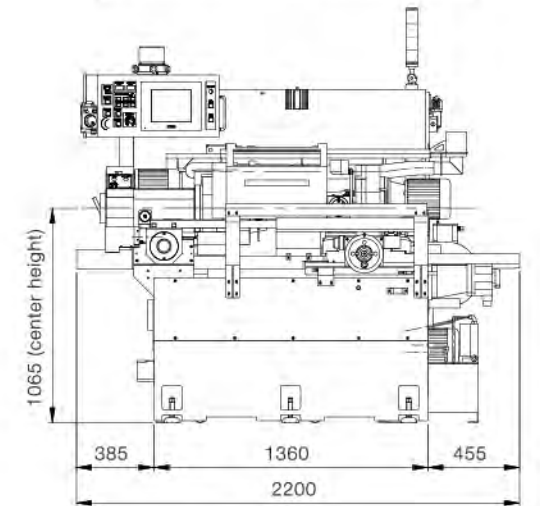
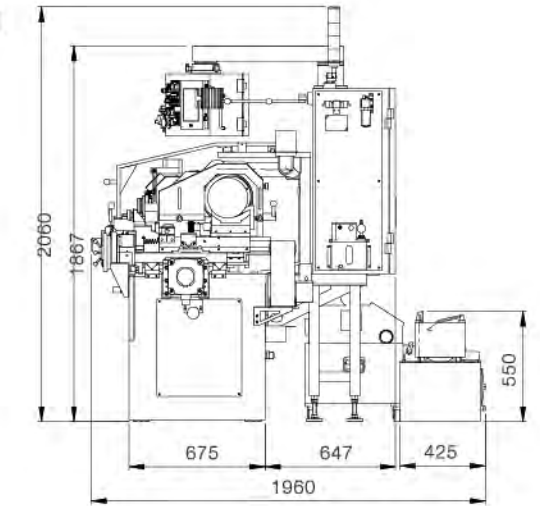

STANDARD ACCESSORIES

- NC control ---1
- Hydraulic system ---1
- Coolant system ---1
- Diamond dresser ---1
- Splash guard ---1
- Belt tension auto. adjustment ---1
- Tool box and kits ---1
- Grinding wheel spindle ---1 (alternative of 10,000~30,000 r.p.m.)

OPTIONAL ACCESSORIES

- Hydraulic 3-jaw chuck
- Adjustable 3-jaw scroll chuck
- Magnetic coolant separator
- Paper filter
- Face grinding attachment
- Wheelhead oil lubricator
- Spare internal spindle
- Oil cooler
- Rotary dresser
- Soft jaw machining device
- Built-in type grinding wheel spindle 80,000 r.p.m. with ER11 for dia. 6~12mm (for IG-150-2NC)
- Built-in type grinding wheel spindle 110,000 r.p.m. with ER11 for dia. 3~7mm (for IG-150-2NC)



**WORK LAMP
(MOUNTED ON MACHINE)**



COOLANT SYSTEM



**MAGNETIC COOLANT
SEPARATOR**



**MAGNETIC WITH
PAPER FILTER**



**ADJUSTABLE 3-JAW
SCROLL CHUCK**



HYDRAULIC CHUCK